

## I Application

The HCLB pump is a positive displacement lobular rotating pump of a sanitary design providing high performance and maximum reliability with a reduced size.

This pump is perfect for managing all kinds of fluid, of either low or high viscosity, in the food-processing, dairies, and cosmetic industries as well as for filtering and bottling applications. Fluids containing fragile solids such as junket, can be pumped without damage thanks to the specially designed lobes.

## I Operating principle

The HCLB pumps basically consist of two lobe rotors which rotate synchronously inside a casing without touching each other.

As the rotors rotate, the spaces between the lobes and the casing are successively filled with fluid, which is transported to the discharge nozzle with a fixed amount of displacement. The pumped fluid forms a continuous stream thanks to the tolerances between the lobes and the pump casing, thus ensuring an efficient pumping.

## I Design and features

Close-coupled construction.

Casing and cover in stainless steel (investment casting).

Tri-lobe rotors.

Sanitary design of the attachment of the rotors.

DIN connections.

Sanitary mechanical seals.

Easy cleaning and maintenance.

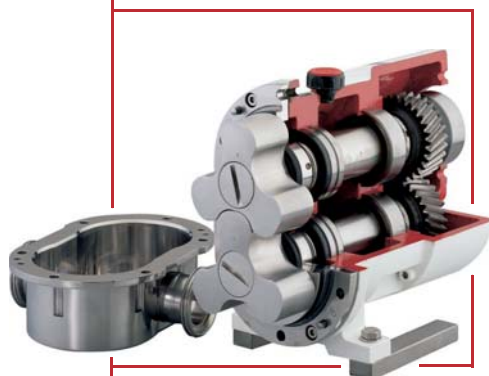

## I Materials

Parts in contact with the product	AISI 316L
Other parts	AISI 304
Support	GG-15
Gaskets	EPDM in compliance with FDA
Mechanical seals	C/SiC/EPDM
Internal surface finish	Ra < 0.8 μm
External surface finish	bright polish



**I Options**

- Mech.seals in SiC/SiC, TgC/SiC, C/StSt.
- Packing with lip seal.
- Gaskets: FPM.
- External by-pass.
- Bi-wing lobes.
- AISI 304 drive shroud.
- Several kinds of drives and protections (gearbox drive with optional frequency converter pulley drive speed selector).
- Trolley and/or switchboard.
- Connections: Clamp, SMS, RJT, etc.

**I Technical specifications**

Max. flow	41 m <sup>3</sup> /h	180 GPM
Max. pressure	12 bar	174 PSI
Max. working temperature	120 °C	248°F
Max. speed	950 rpm	
Max. differential pressure:		
HCLB 1-25, 2-40, 3-50	12 bar	174 PSI
HCLB 1-40, 2-50, 3-80	7 bar	102 PSI

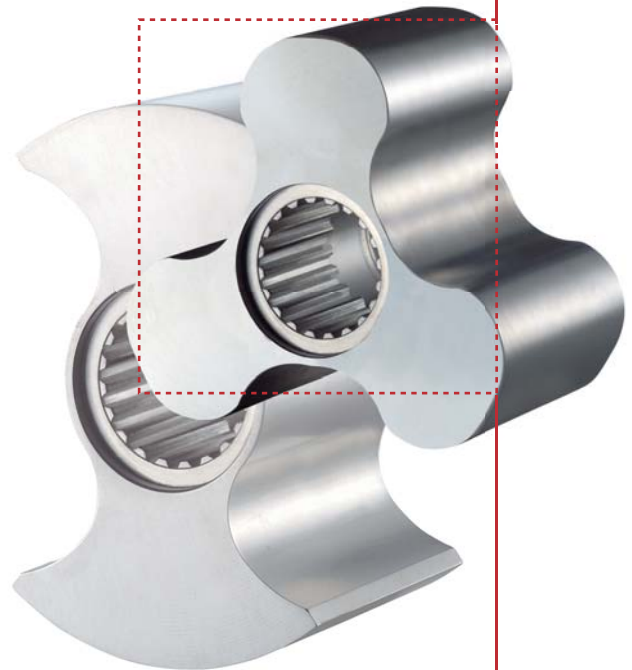

**I General dimensions**

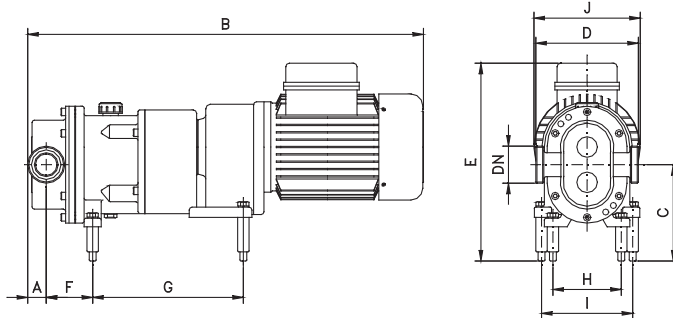

TYPE	Motor gear		DN	A	B	C	D (*)	E	F	G	H	I	J
	kW	Size											
HCLB 1-25	0,55 - 0,75	SK 01/80	25	26	600	150	158	295	71	275	105	105	181
	1,1 - 1,5	SK 01/90	1"		650			300					
HCLB 1-40	0,75	SK 01/80	40	33	615	170	166	295	77	265	120	160	203
	1,1 - 1,5	SK 01/90			665			300					
HCLB 2-40	1,1 - 1,5	SK 20/90	1½"	33	695	170	190	325	82	265	120	160	203
	2,2	SK 20/100			725			355					
HCLB 2-50	1,5	SK 20/90	50	39	705	227	194	325	87	265	120	160	203
	2,2	SK20/100			735			355					
HCLB 3-50	2,2 - 3	SK25/100	2"	39	840	227	239	435	97	427	160	155	228
	4	SK25/112			863			445					
HCLB 3-80	5,5	SK33/132	80	55	920	227	239	470	97	413	160	175	266
	3	SK30/100			865			435					
HCLB 3-80	4	SK30/112	80	55	890	227	256	445	108	348	160	185	228
	5,5 - 7,5	SK33/132			945			470					

(\*) Dimensions with DIN 11851 connections

